

Pressure switch MDR 3



Pressure switch MDR 3

3-phase
 Switching capacity 7.5 (11) kW
 Available with overload relay
 Max. cut-out pressure 35 bar
 3-pole (N.C.)
 Acc. to EN 60947
 UL / CSA-approval

Type overview MDR 3

Order reference	ON / OFF Rotary knob	Pressure range P _{OFF} in bar	Flange	Weight in g	Part No.
MDR-3 DAA AAAA 045A060 XAA XXX	EA	1.3 - 6	G 1/2"	610	212256
MDR-3 GAA AAAA 090A110 XAA XXX	EA	4 - 11	G 1/2"	610	212263
MDR-3 GBA AAAA 090A110 XAA XXX	EA	4 - 11	G 1/4"	610	212270
MDR-3 GEA AAAA 090A110 XAA XXX	EA	4 - 11	F4 1/4"	640	212287
MDR-3 GDA AAAA 090A110 XAA XXX	EA	4 - 11	F4 1/2"	640	212294
MDR-3 DFA AAAA 090A110 XAA XXX	EA	4 - 11	F4 3/8"	640	212300
MDR-3 HAA AAAA 130A160 XAA XXX	EA	6 - 16	G 1/2"	610	212317
MDR-3 HBA AAAA 130A160 XAA XXX	EA	6 - 16	G 1/4"	610	212324
MDR-3 HEA AAAA 130A160 XAA XXX	EA	6 - 16	F4 1/4"	640	212313
MDR-3 HDA AAAA 130A160 XAA XXX	EA	6 - 16	F4 1/2"	640	212348
MDR-3 HFA AAAA 130A160 XAA XXX	EA	6 - 16	F4 3/8"	640	212355
MDR-3 IAA AAAA 215A250 XAA XXX	EA	7.5 - 25	G 1/2"	610	212362
MDR-3 IDA AAAA 215A250 XAA XXX	EA	7.5 - 25	F4 1/2"	640	212379
MDR-3 JAA AAAA 320A350 XAA XXX	EA	12 - 35	G 1/2"	610	229711
MDR-3 JDA AAAA 320A350 XAA XXX	EA	12 - 35	F4 1/2"	640	229728
MDR-3 DAA BAAA 045A060 XAA XXX	-	1.3 - 6	G 1/2"	590	226932
MDR-3 GAA BAAA 090A110 XAA XXX	-	4 - 11	G 1/2"	590	226949
MDR-3 GBA BAAA 090A110 XAA XXX	-	4 - 11	G 1/4"	590	226956
MDR-3 GEA BAAA 090A110 XAA XXX	-	4 - 11	F4 1/4"	620	226963
MDR-3 GDA BAAA 090A110 XAA XXX	-	4 - 11	F4 1/2"	620	226970
MDR-3 DFA BAAA 090A110 XAA XXX	-	4 - 11	F4 3/8"	620	226987
MDR-3 HAA BAAA 130A160 XAA XXX	-	6 - 16	G 1/2"	590	226994
MDR-3 HBA BAAA 130A160 XAA XXX	-	6 - 16	G 1/4"	590	227007
MDR-3 HEA BAAA 130A160 XAA XXX	-	6 - 16	F4 1/4"	620	227014
MDR-3 HDA BAAA 130A160 XAA XXX	-	6 - 16	F4 1/2"	620	227021
MDR-3 HFA BAAA 130A160 XAA XXX	-	6 - 16	F4 3/8"	620	227038
MDR-3 IAA BAAA 215A250 XAA XXX	-	7.5 - 25	G 1/2"	590	227045
MDR-3 IDA BAAA 215A250 XAA XXX	-	7.5 - 25	F4 1/2"	620	227052
MDR-3 JAA BAAA 320A350 XAA XXX	-	12 - 35	G 1/2"	590	229698
MDR-3 JDA BAAA 320A350 XAA XXX	-	12 - 35	F4 1/2"	620	229704

Unloader valves and cable glands for retrofitting see Accessories!



FLOTECH
 Compressor & Vacuum Parts Ltd

Pressure switch MDR 3

Type overview Pressure Switch MDR 3 RM versions, with roller diaphragm

Tight pressure differential

Extended medium resistance

Replacement for MDR 6

Order reference	ON / OFF Rotary knob	Pressure range P _{OFF} in bar	Sucesor of	Flange	Weight in g	Part No.
MDR-3 DAB BAAA 028A035 XAA XXX	-	1.3 - 6	-	G 1/2"	770	229674
MDR-3 GAB BAAA 060A070 XAA XXX	-	4 - 10	MDR 6/11-1/2"	G 1/2"	770	227595
MDR-3 GOB BAAA 060A070 XAA XXX	-	4 - 10	MDR 6/11 -1/2"+1/4"	G 1/2"+1/4"	810	227601
MDR-3 GAB AAAA 060A070 XAA XXX	EA	4 - 10	MDR 6/11 K -1/2"	G 1/2"	800	227632
MDR-3 GOB AAAA 060A070 XAA XXX	EA	4 - 10	MDR 6/11 K-1/2"+1/4"	G 1/2"+1/4"	850	227649
MDR-3 HAB BAAA 145A160 XAA XXX	-	4 - 10	MDR 6/16 -1/2"	G 1/2"	770	227618
MDR-3 HOB BAAA 145A160 XAA XXX	,	6 - 16	MDR 6/16 -1/2"+1/4"	G 1/2"+1/4"	810	227625
MDR-3 HAB AAAA 145A160 XAA XXX	EA	6 - 16	MDR 6/16 K -1/2"	G 1/2"	800	227656
MDR-3 HOB AAAA 145A160 XAA XXX	EA	6 - 16	MDR 6/16 K -1/2"+1/4"	G 1/2"+1/4"	800	227663

Unloader valves and cable glands for retrofitting see Accessories!

Technical Data MDR 3

Technical Data MDR 3 acc. to EN 60947 UL / CSA	
Rated insulation voltage U _i	690 V
Motor switching capacity (UL 508, CSA 22.2) U _e =120 V (1~)	2 HP
Motor switching capacity (AC 3) U _e =240 V (1~)	5.5 kW
Motor switching capacity (UL 508, CSA 22.2) U _e =240 V (1~)	5 HP
Motor switching capacity (AC 3) U _e =240 V (3~)	5.5 kW
Motor switching capacity (UL 508, CSA 22.2) U _e =240 V (3~)	7.5 HP
Motor switching capacity (AC 3) U _e =400 V (3~)	7.5/11* kW
Motor switching capacity (UL 508, CSA 22.2) U _e =480 V (3~)	15 HP
Motor switching capacity (AC 3) U _e =500 V (3~)	7.5/11* kW
Motor switching capacity (UL 508, CSA 22.2) U _e =600 V (3~)	20 HP
Motor switching capacity (AC 3) U _e =690 V (3~)	7.5/11* kW

Technical Data MDR 3 acc. to EN 60947 UL / CSA	
Electrical life (AC 3) Cycles	> 1 x 10 ⁵
Mechanical life Cycles	> 1 x 10 ⁶
Max. electrical cycles Cycles/h	120
Max. mechanical cycles Cycles/h	600
Rated operational current I _e at 240 V AC	24 A
Bursting strength P _z	≤ 16 > 40 bar ≥ 25 > 60 bar
Permissible medium temperature Air	-5...+ 80 °C
Permissible medium temperature Water	+ 80 °C
Degree of Protection acc. to EN 60529	IP 54
Conductor cross-section 1 ... Fine stranded 1 x / 2 x	4 / 2.5 mm ²
Conductor cross-section 1 ... Rigid cable 1 x / 2 x	6 / 4 mm ²

Diaphragm media resistance MDR 3	
Air, Water	resistant

Diaphragm media resistance MDR 3 RM	
Acetylene, Ammonia 25%, Butane, Natural gas, Vinegar 25 %, Ethylene glycol, Glycerol, Urine, Carbon dioxide, Carbonic acid, Air, Vegetable oil, Propane, Silicon oil, Nitrogen, Water, Hydrogen, Sea water	resistant

Diaphragm media resistance MDR 3 USA	
Acetylene, Gasoline, Butane, Diesel, Natural gas, Petroleum, Ethylene glycol, Glycerol, Fuel oil, Urine, Carbon dioxide, Carbonic acid, Air, Mineral oils, Vegetable oil, Propane, Silicon oil, Nitrogen, Synthetic oils, Water, Distilled water, Hydrogen, Sea water, Water steam	resistant

A detailed overview of diaphragm media resistance for all pressure switches can be found in the table on page 2.11

* With arc-chamber Sk... H on demand



FLOTECH

Compressor & Vacuum Parts Ltd

Pressure switch MDR 3

Dimensions MDR 3

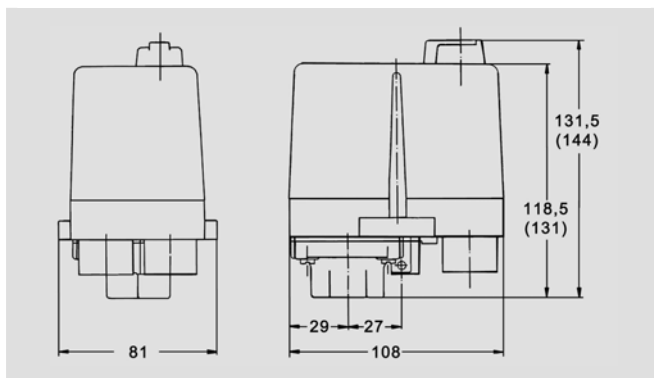

Pressure switch **MDR-3**

Circuit Diagrams MDR 3

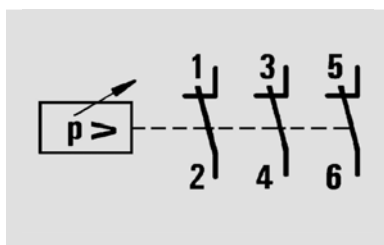

MDR 3

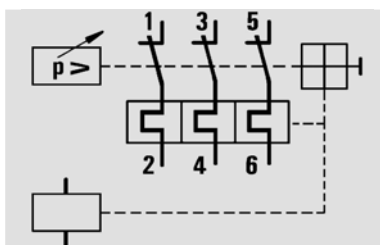

MDR 3 EA 3 R 3 RA 3

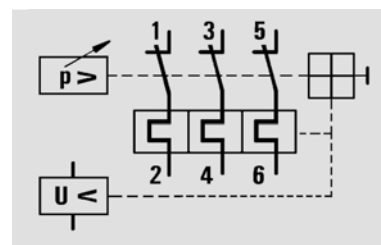

MDR 3 EA 3 R 3 RU 3

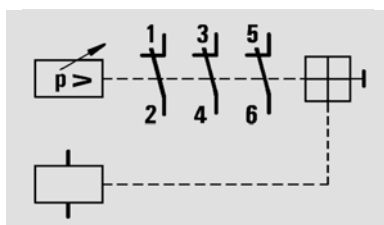

MDR 3 EA 3 RA 3

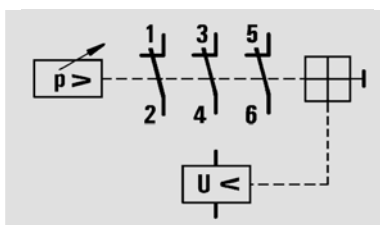

MDR 3 EA 3 RU 3

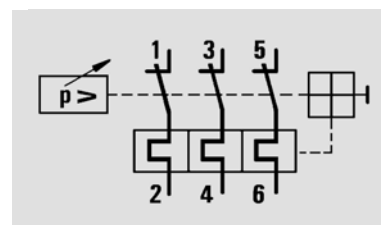

MDR 3 EA 3 R 3

Accessories Hourmeter kit MDR 3



Description

The MDR 3 can be equipped or retrofitted with an operating hourmeter to monitor the pump and compressor running time.

The hourmeter is available as a kit and can be attached to the cover in 4 different positions, each offset at an angle of 90°.

This ensures optimum readability. The kit consists of an operating hourmeter for either 230 V or 400 V and a perforated MDR 3 cover with or without ON/OFF lever.

Type overview Hourmeter kit

Order reference	Description	Voltage	Packing (units)	Part No.
H3 - B 230	Hourmeter and Cover for MDR-3	230 V / 50 Hz	1	237297
H3 - B 400	Hourmeter and Cover for MDR-3	400 V / 50 Hz	1	237303
H3-EA - B 230	Hourmeter and Cover for MDR-3+EA	230 V / 50 Hz	1	237310
H3-EA - B 400	Hourmeter and Cover for MDR-3+EA	400 V / 50 Hz	1	237327



FLOTECH
Compressor & Vacuum Parts Ltd

Pressure switch MDR 3

Accessories MDR 3

Order reference	Description	Weight in g	Part No.
Unloader valves			
EV 3	With screw connection for 6 mm plastic or copper discharge tubes	25	201045
EV 3i	With screw connection for 1/4" plastic or copper discharge tubes	25	201052
EV 3S*	With quick-connect for 6 mm plastic discharge tubes	25	201069
EV 3W*	90° unloader valve with screw connection for 6 mm plastic or copper discharge tubes	18	201076
EV 3Wi*	90° unloader valve with screw connection for 1/4" plastic or copper discharge tubes	18	201083
EV 3WS*	90° unloader valve with quick-connect for 6 mm plastic discharge tubes	10	201090
EV 3L	With screw connection for 6 mm plastic or copper discharge tubes	30	201229
Delayed unloader valves			
AEV 3	With screw connection for 6 mm plastic or copper discharge tubes	25	201106
AEV 3S*	With quick-connect for 6 mm plastic discharge tubes	25	201120
AEV 3W*	90° unloader valve with screw connection for 6 mm plastic or copper discharge tubes	18	201137
AEV 3Wi*	90° unloader valve with screw connection for 1/4" plastic or copper discharge tubes	18	201144
AEV 3WS*	90° unloader valve with quick-connect for 6 mm plastic discharge tubes	10	201151
Cable glands			
PG 9 Z	With strain relief (for additional wiring)	12	201373
WN	Grommet	6	201243
PG 11 G	Conduits for mounting of cable glands (Inner thread)	6	201250
PG 11 V	Cable gland complete	12	201267
PG 11 Z	With strain relief	12	201274
PG 11 ZK	With strain relief and cable support	12	201281
PG 13.5 G	Conduits for mounting of cable glands (Inner thread)	6	201298
PG 13.5 V	Cable gland complete	12	201304
PG 13.5 Z	With strain relief	12	201311
PG 13.5 ZK	With strain relief and cable support	12	201328
PG 16 G	Conduits for mounting of cable glands (Inner thread)	6	201335
PG 16 V	Cable gland complete	12	201342
PG 16 Z	With strain relief	12	201359
PG 16 ZK	With strain relief and cable support	18	201366
MW	Mounting bracket	65	230021
Cover			
H3 (Cover MDR 3)	Cover without rotary knob (Neutral version, without marking)	100	229490
H3-EA (Cover MDR 3+EA)	Cover with rotary knob for manual On/Off (Neutral version, without marking)	100	230007
Thermal, 3-pole overload relay			
SK 3	Arc-chamber without lock mechanism (supplied as standard with MDR 3...)	90	201380
SK 3-S	SK 3-S Arc-chamber with lock mechanism (supplied as standard with MDR 3...+EA)	110	201397
SK R3/ 1,0	0.63 – 1.00 A	145	201403
SK R3/ 1,6	1.00 – 1.60 A	145	201410
SK R3/ 2,5	1.60 – 2.50 A	145	201427
SK R3/ 4,0	2.50 – 4.00 A	145	201434
SK R3/ 6,3	4.00 – 6.30 A	145	201441
SK R3/ 10,0	6.30 – 10.00 A	145	201458
SK R3/ 16,0	10.00 – 16.00 A	145	201465
SK R3/ 20,0	16.00 – 20.00 A	145	201472
SK R3/ 24,0	20.00 – 24.00 A	145	201489
SK R3/ 30/2	22.00 – 30.00 A, 2 pole	145	201496
Undervoltage and shunt releases			
RU 3/24-50	Undervoltage release 24 V, 50 Hz	100	226857
RU 3/230-50	Undervoltage release 230 V, 50 Hz	100	201540
RU 3/400-50	Undervoltage release 400 V, 50 Hz	100	201557
RA 3/24-50	Shunt release 24 V, 50 Hz	100	201564
RA 3/110-50	Shunt release 110 V, 50 Hz	100	201571
RA 3/230-50	Shunt release 230 V, 50 Hz	100	201588
RA 3/240-60	Shunt release 240 V, 60 Hz	100	214113
RA 3/400-50	Shunt release 400 V, 50 Hz	100	225935
RA 3/480-60	Shunt release 480 V, 60 Hz	100	201595

*up to ≤16 bar



FLOTECH
Compressor & Vacuum Parts Ltd

Pressure switch MDR 3

Unloader valves / Delayed unloader valves



EV 3 / EV 3i



EV 3S



AEV 3S



AEV 3



EV 3L



EV 3W / EV 3Wi



AEV 3W / AEV 3Wi



EV 3WS



AEV 3WS

Cable glands MDR 3



WN



PG .. G



PG .. V



PG .. Z



PG .. ZK

Wall-mounting bracket, 3-pole overload relay, Undervoltage and shunt releases



MW 3



SK 3



SK 3-S



SK R3 / ..



RU ..



RA ..

Pg 9 Z



Pressure switch MDR 3

Dimensions, Accessories MDR 3

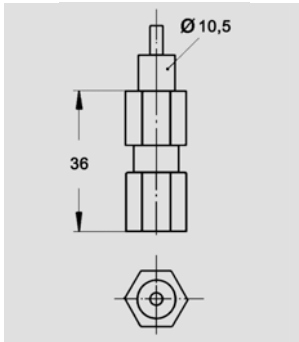

EV 3 / EV 3i

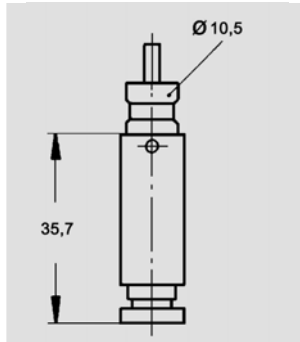

EV 3S

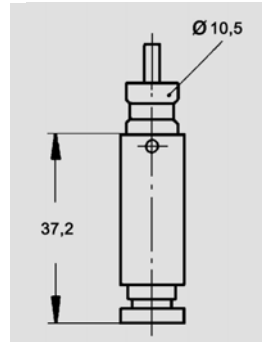

AEV 3S

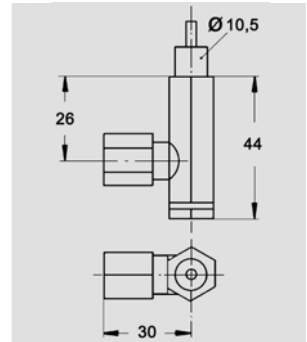

AEV 3

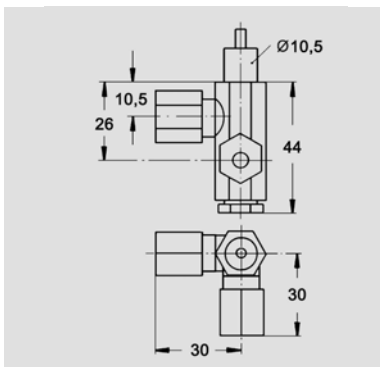

EV 3L

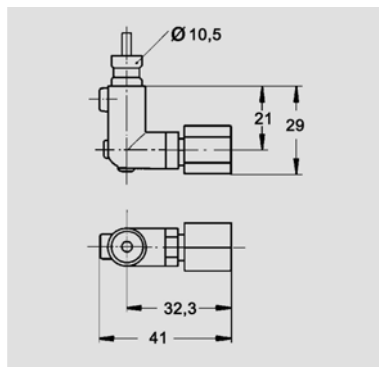

EV 3W / EV 3Wi
AEV 3W / AEV 3Wi

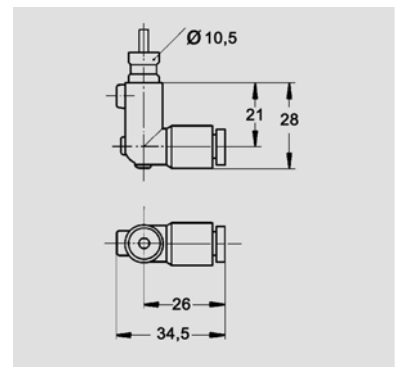

EV 3WS / AEV 3WSi

Tripping curves R3 (average)

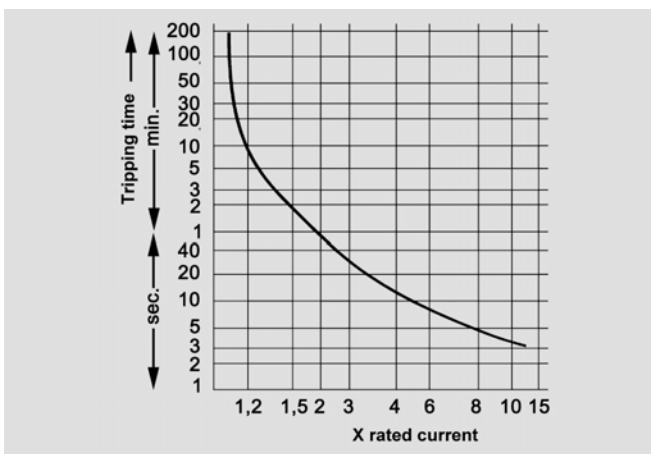

FLOTECH

Compressor & Vacuum Parts Ltd

Pressure switch MDR 3

Pressure Diagrams MDR 3

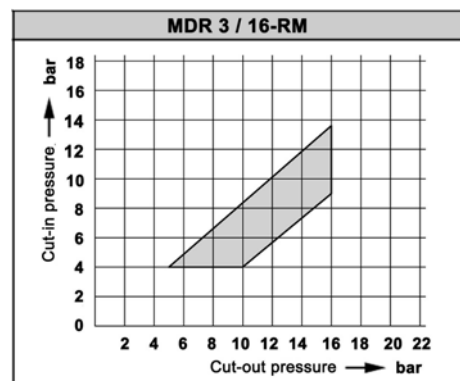
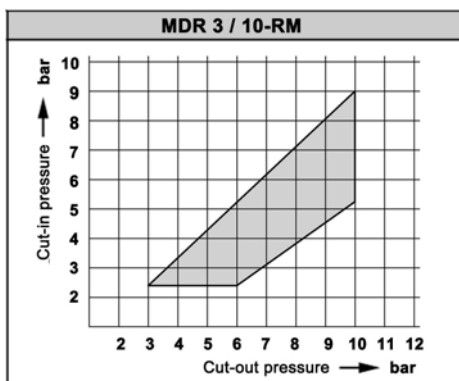
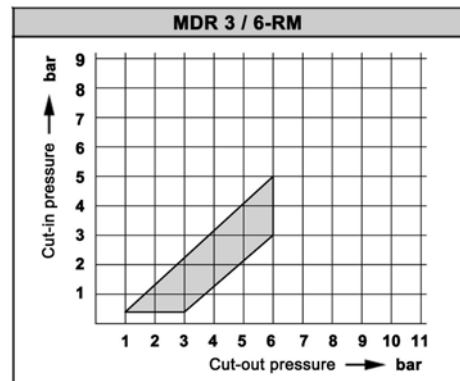
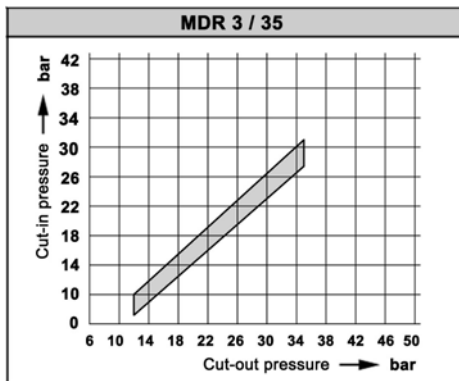
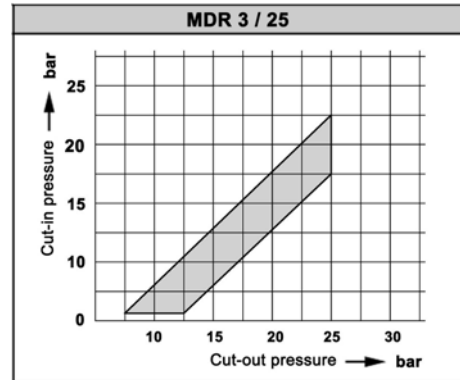
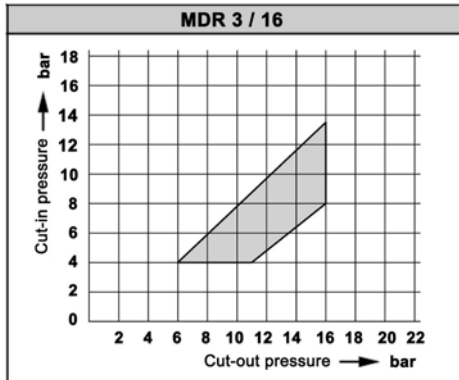
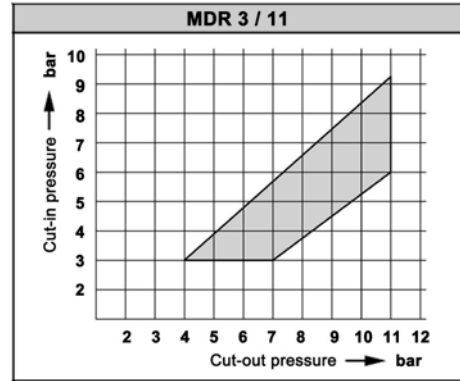
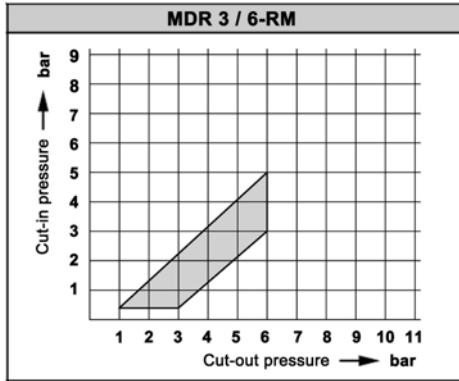

FLOTECH

Compressor & Vacuum Parts Ltd